

**Driver's Guide
for the
CRATE LIMO
TX50D
battery powered amplifier**



Powerful, Portable Tone with Style!

CRATE TX50D

CONGRATULATIONS!

You are now the proud owner of the Crate TX50D battery powered amplifier with Digital Signal Processing. At last, you can take your music with you and have great tone on the road. Not only is the TX50D compact and portable, it also sports two separate channels and the incredible sound that has made Crate a household name among musicians.



Your Crate amplifier is designed by musicians and built using the finest components available. Each unit is rigorously tested by skilled technicians and musicians to ensure that your amplifier is the best it can be!

In order to get the most out of your new amplifier, we strongly urge you to go over the information contained in this manual before you begin playing.

Thanks for choosing **CRATE**.

CONTENTS:

Features	3
About the Power Supply	4,5
The Front Panel	6,7
The Rear Panel	8
About the Insert Jack	8
Suggested Setups	9,10
System Block Diagram	11
Technical Specifications	back cover

 CAUTION RISK OF ELECTRIC SHOCK DO NOT OPEN	 PRECAUCION RIESGO DE CORRIENTAZO NO ABRA	 ATTENTION RISQUE D'ELECTROCUTION NE PAS OUVRIR		
<small>WARNING: TO REDUCE THE RISK OF FIRE OR ELECTRIC SHOCK, DO NOT EXPOSE THIS APPARATUS TO RAIN OR MOISTURE. TO REDUCE THE RISK OF ELECTRIC SHOCK, DO NOT REMOVE COVER. NO USER-SERVICEABLE PARTS INSIDE. REFER SERVICING TO QUALIFIED SERVICE PERSONNEL.</small>	<small>PRECAUCION: PARA REDUCIR EL RIESGO DE INCENDIOS O DESCARGAS ELECTRICAS, NO PERMITA QUE ESTE APARATO QUEDE EXPUESTO A LA LLUVIA O LA HUMEDAD. PARA DISMINUIR EL RIESGO DE CORRIENTAZO, NO ABRA LA CUBIERTA. NO HAY PIEZAS ADENTRO QUE EL USUARIO PUEDO REPARAR DEJE TODO MANTENIMIENTO A LOS TECNICOS CALIFICADOS.</small>	<small>ATTENTION: PROTEGEZ CET APPAREIL DE LA PLUIE ET DE L'HUMIDITE AFIN D'EVITER TOUT RISQUE D'INCENDIE OU D'ELECTROCUTION. POUR REDUIRE D'ELECTROCUTION NE PAS ENLEVER LE COUVERCLE. AUCUNE PIECE INTERNE N'EST REPRABLE PAR L'UTILISATEUR. POUR TOUTE REPARATION, S'ADRESSER A UN TECHNICIEN QUALIFIE.</small>		
IMPORTANT SAFETY INSTRUCTIONS				
<ul style="list-style-type: none"> • READ, FOLLOW, HEED, AND KEEP ALL INSTRUCTIONS AND WARNINGS. • DO NOT OPERATE NEAR ANY HEAT SOURCE AND DO NOT BLOCK ANY VENTILATION OPENINGS ON THIS APPARATUS. FOR PROPER OPERATION, THIS UNIT REQUIRES 3" (75mm) OF WELL VENTILATED SPACE AROUND HEATSINKS AND OTHER AIR FLOW PROVISIONS IN THE CABINET. • DO NOT USE THIS APPARATUS NEAR SPLASHING, FALLING, SPRAYING, OR STANDING LIQUIDS. • CLEAN ONLY WITH LINT-FREE DAMP CLOTH AND DO NOT USE CLEANING AGENTS. • ONLY CONNECT POWER CORD TO A POLARIZED, SAFETY GROUNDED OUTLET WIRED TO CURRENT ELECTRICAL CODES AND COMPATIBLE WITH VOLTAGE, POWER, AND FREQUENCY REQUIREMENTS STATED ON THE REAR PANEL OF THE APPARATUS. • PROTECT THE POWER CORD FROM DAMAGE DUE TO BEING WALKED ON, PINCHED, OR STRAINED. • UNPLUG THE APPARATUS DURING LIGHTNING STORMS OR WHEN UNUSED FOR LONG PERIODS OF TIME. • ONLY USE ATTACHMENTS, ACCESSORIES, STANDS, OR BRACKETS SPECIFIED BY THE MANUFACTURER FOR SAFE OPERATION AND TO AVOID INJURY. • WARNING: TO REDUCE THE RISK OF ELECTRIC SHOCK OR FIRE, DO NOT EXPOSE THIS UNIT TO RAIN OR MOISTURE. • SERVICE MUST BE PERFORMED BY QUALIFIED PERSONNEL. • OUR AMPLIFIERS ARE CAPABLE OF PRODUCING HIGH SOUND PRESSURE LEVELS. CONTINUED EXPOSURE TO HIGH SOUND PRESSURE LEVELS CAN CAUSE PERMANENT HEARING IMPAIRMENT OR LOSS. USER CAUTION IS ADVISED AND EAR PROTECTION IS RECOMMENDED IF UNIT IS OPERATED AT HIGH VOLUME. • WARNING: THIS UNIT REQUIRES A SAFETY GROUNDED OUTLET WIRED TO CURRENT ELECTRIC CODES HAVING THE LINE SUPPLY VOLTAGE, POWER, AND FREQUENCY IDENTIFIED ON THE REAR OF THE UNIT. THE OUTLET MUST REMAIN ACCESSIBLE TO DISCONNECT THE UNIT IF A FAULT SHOULD ARISE WHILE IN USE. THIS UNIT SHOULD BE UNPLUGGED WHEN NOT IN USE. 				
<small>EXPLANATION OF GRAPHICAL SYMBOLS: EXPLICACION DE SIMBOLOS GRAFICOS: EXPLICATION DES SYMBOLES GRAPHIQUES:</small>	 =	<small>"DANGEROUS VOLTAGE" "VOLTAJE PELIGROSO" "DANGER HAUTE TENSION"</small>	 =	<small>"IT IS NECESSARY FOR THE USER TO REFER TO THE INSTRUCTION MANUAL" "ES NECESARIO QUE EL USUARIO SE REFIERA AL MANUAL DE INSTRUCCIONES." "REFERREZ-VOUS AU MANUAL D'UTILISATION"</small>



CRATE TX50D

FEATURES:

- Two separate channels
- Crate's Digital Signal Processing (DSP)
- Insert jack for connecting external effects
- CD Inputs for connecting background music
- Footswitch control of channel selection and DSP on/off
- Headphones jack for silent operation
- Internal rechargeable power supply for up to 8 hours of normal playing time, 2 hours at full output – fully recharges within 6 hours (when battery is fully discharged; shorter if partially charged)
- Can also be powered by an AC wall adapter (supplied) or by a 12 volt vehicle car adapter (included – see page 5)
- Two-color battery status LED – red indicates low battery, yellow indicates battery okay
- Tuned port cabinet for extended bass response; 10" woofer and 2" Piezo tweeter for full range sound with clear highs
- Durable black or platinum Tolex® covering
- Complete set of rubber feet on three different sides – for positioning as a low angle monitor, a high angle monitor or as an upright speaker (see below)
- Stand mount adapter (1-1/2" diameter) for PA use (see below)

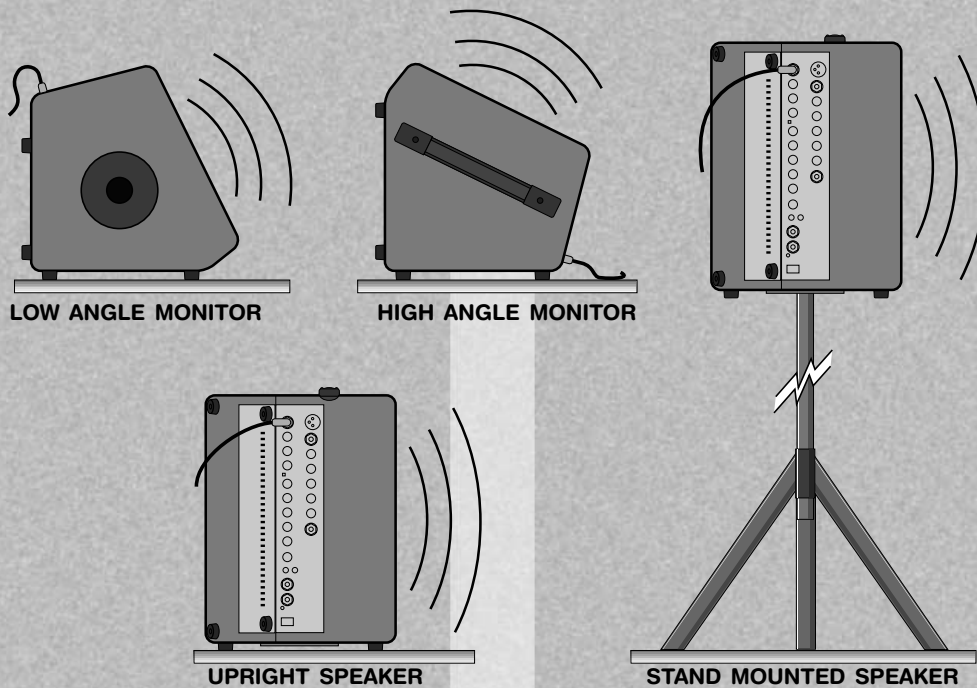

CRATE *TX50D*

ABOUT THE POWER SUPPLY:

The TX50D uses a sealed lead-acid 12-volt battery as its internal power source. Unlike ni-cad batteries, this battery has no “memory” – it can be fully recharged at any time, without damage to the battery.

When fully charged, the LED next to the power switch will glow yellow with the switch at the on (“I”) position. The LED will change to red when the battery is low and needs recharging. When this happens, turn the amp off, connect the 15-volt charger to the charger jack and plug it in. The LED near the charger jack will glow red while the amp is charging and goes out when the amp is fully charged. The battery fully recharges within 6 hours, providing up to 8 hours of use at low levels, about 4 hours of use at moderate levels, and about 2 hours of use at continuous full power (sine wave). The battery is rated for up to 1000 charging cycles. The charger can also function as an AC power supply.

The battery inside the TX50D must be fully charged before operating the amplifier for the first time. Even though the amplifier leaves our factory with a charged battery, time spent in shipping may cause the battery to lose some of its charge.

WARNING! Never connect the supplied 15VDC charger to the amplifier’s 12VDC Cigarette Lighter Adapter jack! Damage to the amplifier may occur!

NOTE: If the battery is drained too low, the Power LED will go out. This indicates an exhausted battery – one which may not take a charge. If this happens, turn the amp off, connect the 15-volt charger to the charger jack and plug it in. If the Charger LED (see #25, page 8) doesn’t illuminate, the battery might be beyond recharging. (The TX50D uses a “smart” charging circuit and will not allow you to charge a defective battery.) If the battery is serviceable, the LED will glow once the battery reaches 10 volts – leave the charger plugged in and let the battery fully recharge. If the LED never illuminates, the battery may need replacing. Contact Crate’s service department:

SLM Electronics
1901 Congressional Drive
St. Louis, MO 63146
1-800-738-PARTS (7563)

CRATE TX50D

ABOUT THE POWER SUPPLY (continued):

The TX50D may also be powered by using a 12-volt vehicle cigarette lighter adapter, available at most electronic supply stores. Make certain that the polarity on the adapter matches what is shown below.



Connect the small round end of the adapter to the 12VDC Automobile adapter jack (#26, page 8), then plug the other end of the adapter into the vehicle's cigarette lighter socket. (In some vehicles, the ignition switch must be in the "on" or "accessory" position to have power at the socket.) **NEVER PLUG THE SUPPLIED 15VDC CHARGER INTO THE AMPLIFIER'S 12VDC LIGHTER PLUG!**

When using the DC cigarette lighter adapter, the vehicle's battery will keep the amp charged to its voltage level – if the battery has a 13.5-volt charge, the amp will charge up to 13.5 volts; if the battery is low and only has a 10-volt charge, the amp will discharge down to 10 volts.

CAUTION! The TX50D contains a sealed, rechargeable, lead-acid battery. Improper disposal of battery or replacement with any other type may cause leakage, explosion, and/or injury. See page 4 for additional information. Also, refer to product warranty information.

This equipment has been tested and found to comply with the limits for a Class B digital device, pursuant to part 15 of the FCC Rules. These limits are designed to provide reasonable protection against harmful interference in a residential installation. This equipment generates, uses and can radiate radio frequency energy and, if not installed and used in accordance with the instructions, may cause harmful interference to radio communications. However, there is no guarantee that interference will not occur in a particular installation. If this equipment does cause harmful interference to radio or television reception, which can be determined by turning the equipment off and on, the user is encouraged to try to correct the interference by one or more of the following measures:

- Reorient or relocate the receiving antenna.
- Increase the separation between the equipment and the receiver.
- Connect the equipment into an outlet on a circuit different from that to which the receiver is connected.
- Consult the dealer or an experienced radio/TV technician for help.

Changes or modifications to this device not expressly approved by SLM Electronics could void the user's authority to operate the equipment under FCC rules.

Declaration of Conformity

Manufacturer's Name: SLM Electronics
Corporate Headquarters: 1901 Congressional Drive, St. Louis, Missouri 63146
Primary Production Facility: 700 Hwy 202 W, Yellville, Arkansas, 72687
Product Type: Audio Amplifier

Products meet the regulations for compliance marking under:

ETL standards UL6500, UL60065, or UL813
CSA standards E60065 or C22.2 No.1-M90
CE safety standard EN60065
CE EMC standards EN55103 or EN55013 and EN61000
C-tick designation Level 2, ABN #56748810738, ARBN# N222
KETI standard K60065 (limited model approval)

Compliance Support Contact: SLM Electronics, Attn: R&D Compliance Engineer
1901 Congressional Drive, St Louis, Missouri, 63146 • Tel.: 314-569-0141, Fax: 314-569-0175

CRATE TX50D

THE FRONT PANEL:

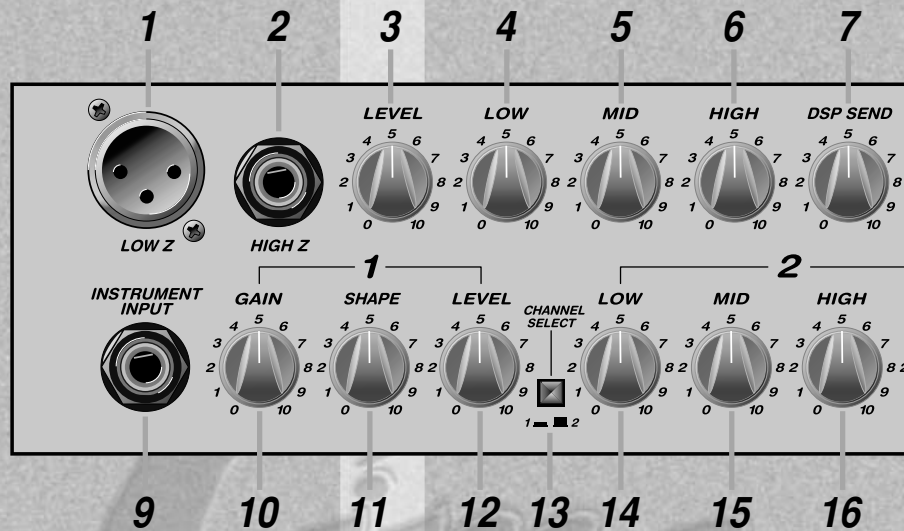

1. **LOW Z:** Connect a low impedance microphone here by means of a shielded signal cable terminated with an XLR type connector.

2. **HIGH Z:** Connect a high impedance microphone here by means of a shielded signal cable terminated with a 1/4" connector.

3. **LEVEL:** Use this control to adjust the level of the mic channel.

4. **LOW:** Use this control to adjust the low frequency level for the mic channel.

5. **MID:** Use this control to adjust the mid frequency level for the mic channel.

6. **HIGH:** Use this control to adjust the high frequency level for the mic channel.

7. **DSP SEND:** Use this control to adjust the amount of signal sent to the internal Digital Signal Processor (DSP) for the mic channel.

8. **INSERT:** Use this jack to connect an external effects device to the amplifier. This is a stereo 1/4" jack, wired as follows:

Tip = Line In (Return - from effect out)

Ring = Line Out (Send - to effect in)

Sleeve = ground

More information on the Insert jack can be found on page 8.

9. **INSTRUMENT INPUT:** Connect an instrument, tape player, CD player, or high impedance microphone here by means of a shielded signal cable terminated with a 1/4" connector.

10. **GAIN (Active only with the Channel Select switch depressed):** Use this control to adjust the gain for the instrument channel 1 - the lower the setting, the lower the amount of distortion. As this control is rotated clockwise, the distortion increases and the output signal becomes louder.

11. **SHAPE (Active only with the Channel Select switch depressed):** Use this control to adjust the tone of the instrument channel 1. Rotating this control counter clockwise enhances mid frequencies; rotating it clockwise enhances the low and high frequencies.

12. **LEVEL (Active only with the Channel Select switch depressed):** Use this control to adjust the output level of the instrument channel 1.

13. **CHANNEL SELECT:** Use this switch to select channel 1 or 2 for the instrument input. With this switch depressed, the Gain, Shape, and Level controls (#10 - 12) are active. With this switch in the out position, the Low, Mid, High, and Level controls (#14 - 17) are active. Channel 1 is typically used for electric guitars since the Gain control can be cranked to produce heavily overdriven distortion.

CRATE TX50D



14. **LOW** (Active only with the Channel Select switch out): Use this control to adjust the low frequency level for the instrument channel 2.

15. **MID** (Active only with the Channel Select switch out): Use this control to adjust the mid frequency level for the instrument channel 2.

16. **HIGH** (Active only with the Channel Select switch depressed): Use this control to adjust the high frequency level for the instrument channel 2.

17. **LEVEL** (Active only with the Channel Select switch out): Use this control to adjust the output level of the instrument channel 2.

18. **DSP SEND**: Use this control to adjust the amount of signal sent to the internal Digital Signal Processor (DSP) for the instrument channel.

19. **DSP MODE**: Use this control to select the type of Digital Signal Processing (DSP) effect applied to the signal. The nomenclature around the control is as follows:

BYPASS: No effect applied

SLAP: Moderate slapback delay

DELAY: Moderate delay with regeneration

ECHO: Long delay with regeneration

CHORUS: Moderate chorus effect

ROTARY: Simulated rotating speaker effect

CHO/HALL: Chorus combined with large reverb

ROOM: Small reverb effect

HALL: Large reverb effect

20. **CD INPUT**: Use these jacks to connect the outputs of a CD player or tape player to the amplifier. The output of the CD or tape player may need to be attenuated for a suitable mix with the input channels – see the notes on page 10.

21. **FOOTSWITCH**: Use this jack to connect a footswitch to the amplifier for remote control of the Instrument channel selection and turning the DSP on and off. The jack is wired as follows:

Tip = Instrument channel selection

Ring = DSP control

Sleeve = ground

22. **HEADPHONES**: Use this jack to connect a pair of stereo headphones for private practice sessions. The internal speakers are disconnected when headphones are used.

23. **LED**: This LED illuminates yellow when the power switch is at the on position – when the amp is fully charged. The LED illuminates red when the battery needs recharging.

24. **POWER**: Use this switch to turn the amplifier on (top of the switch depressed) and off (bottom of switch depressed).

CRATE TX50D

THE REAR PANEL:

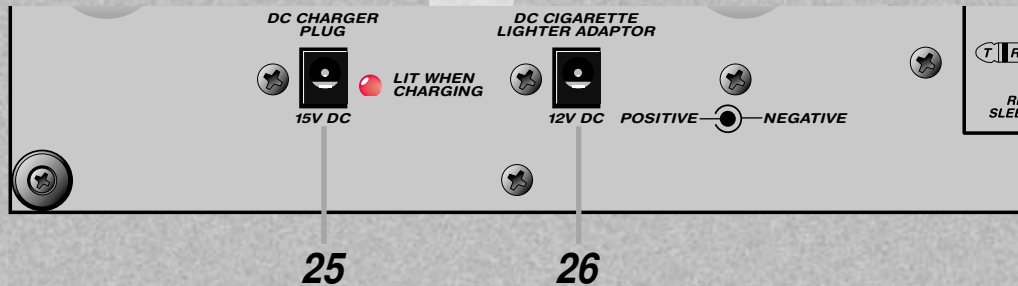

25. DC CHARGER PLUG, 15VDC: Plug the small round connector of the supplied AC wall adapter into this jack to charge the internal battery. The LED next to the jack glows red when the amp is charging. See page 4 for additional information.

26. DC CIGARETTE LIGHTER ADAPTER, 12 VDC: Plug the small round connector of the optional 12-volt car adapter into this jack to play the amplifier from a vehicle, without using the internal battery. NEVER connect the supplied 15-volt charger to this jack! See page 4 for additional information.

ABOUT THE INSERT JACK:

The Insert jack (#8) lets you patch external effects into the amplifier just prior to its power amp stage, as shown below. Set the mix controls on the external effects units to "full effect" (100% wet).

Connecting to the effect's insert jack with a stereo cable:

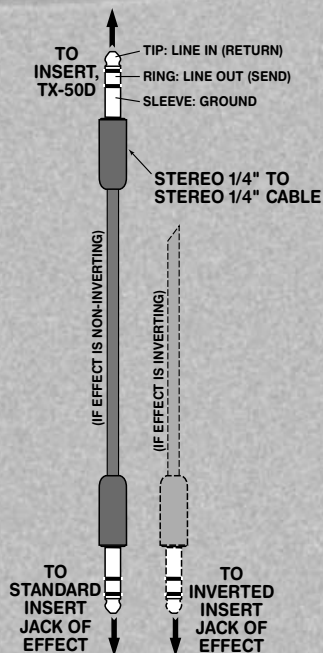

Connecting to the effect with a stereo-to-mono Y-cable:

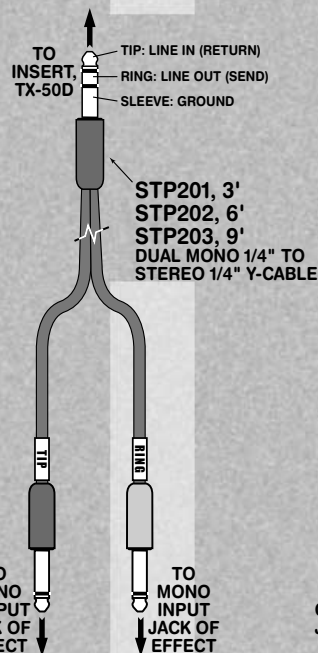

Connecting to the effect with a stereo-to-mono adapter and cables:

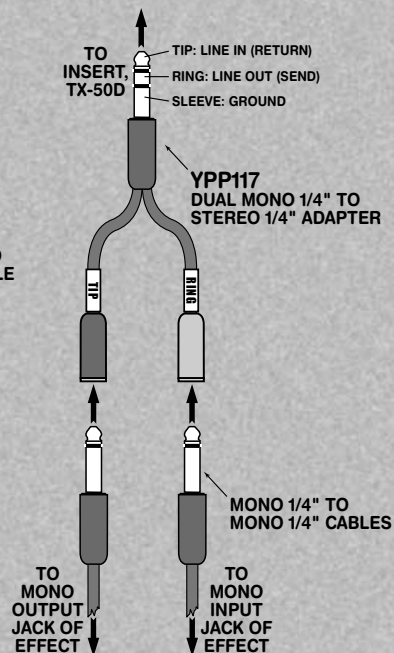

CRATE TX50D

SUGGESTED SET-UPS:

The TX50D can be used in a variety of different ways, some of which are shown below and on the following page. Use these ideas to fuel your imagination for the setup which best suits your needs.

Idea 1 – Play and sing, with external effects and backup: Connect a microphone to the Low Z jack. Connect an instrument (acoustic or electric guitar, keyboard) to the Instrument Input jack. (This high-Z input works with all types of pickups, from Piezo to active types.) Connect a rhythm machine to the CD Input jacks. A two-button footswitch may be used to select Instrument Channel 1 or 2 and to turn the DSP on and off. Connect the external effects device to the Insert jack using one of the methods shown on page 8. (Note that the external effect will be applied equally to both channels, as well as the CD inputs, so use with discretion.)

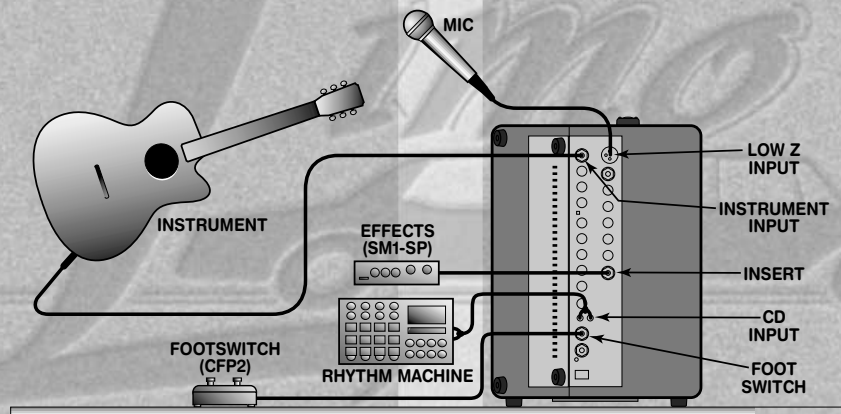

Idea 2 – Play along: Connect an instrument (acoustic or electric guitar, keyboard) to the Instrument Input jack. Connect a tape player or CD player to either the CD Input jacks or to the Low Z jack of the remaining channel. (See the notes on page 10 for more detailed information.) A pair of stereo headphones may be connected to the Headphones jack for privacy.

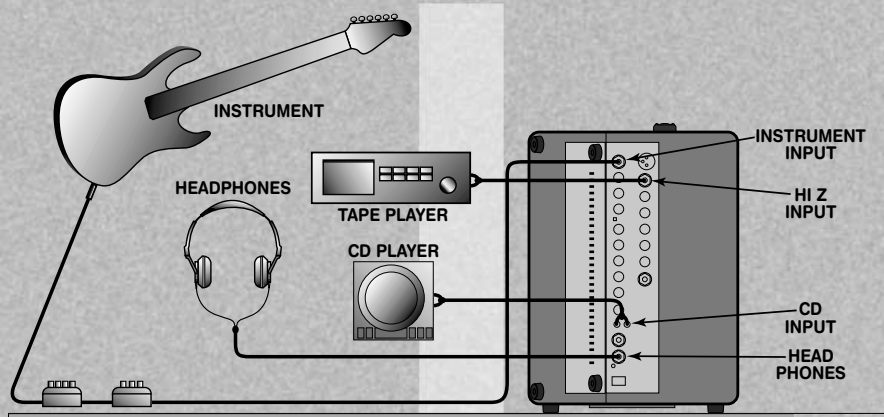

CRATE TX50D

SUGGESTED SET-UPS (continued):

Idea 3 – Sing along: Connect a low impedance microphone to the Low Z jack. Connect a high impedance microphone to the Instrument Input jack. Connect a tape player (for sound tracks and back up music) to the CD Input jacks. A single button footswitch may be used to turn the DSP on and off.

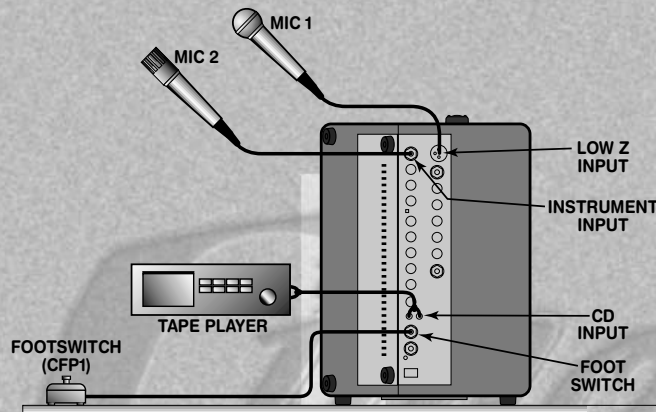

Notes:

- When a tape player or CD player is connected to the CD Input jacks, the output of the player may need to be adjusted by means of its output level control (if it has one), or by an external attenuator/preamp.
- A tape player or CD player may be connected to either channel instead of to the CD Input jacks. This provides control of the gain and equalization of the signal, as well as the application of DSP if desired. In this case, the left and right outputs of the tape or CD player must be summed to create a mono signal, such as shown below.

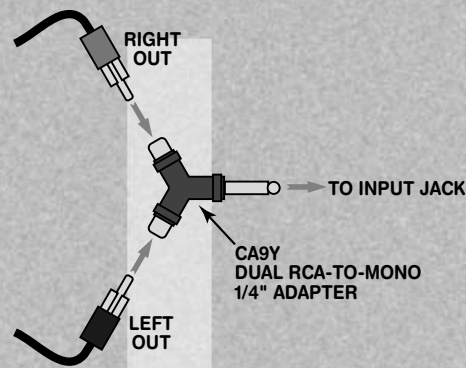

CRATE TX50D

SYSTEM BLOCK DIAGRAM:

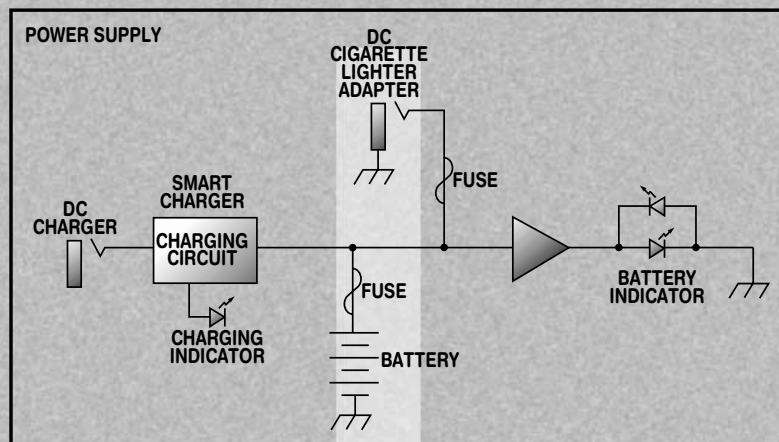
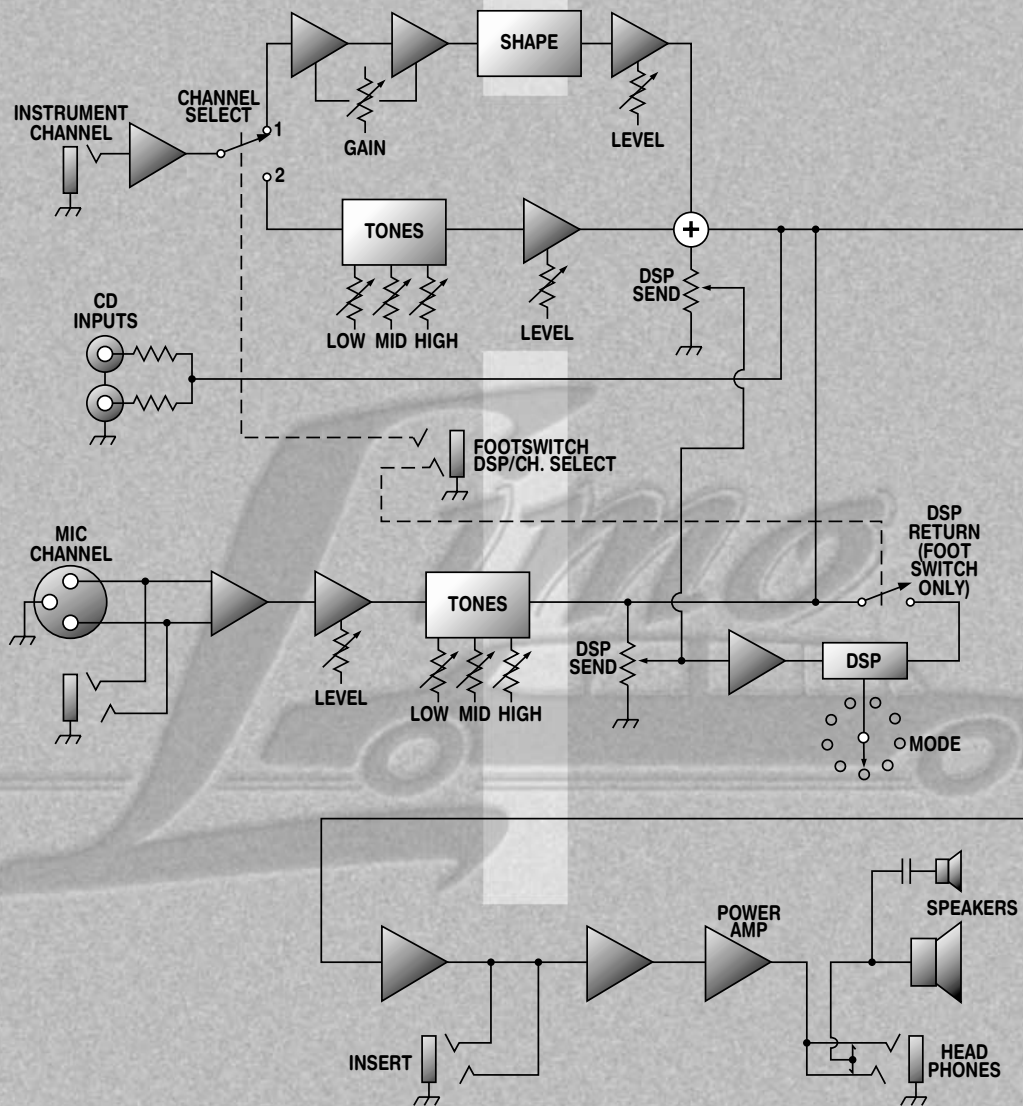

CRATE TX50D

TECHNICAL SPECIFICATIONS

OUTPUT POWER RATING 50W RMS @ 10% THD, 4 ohms, 13.6VDC in

INPUT IMPEDANCE 1M ohm

MAXIMUM SIGNAL ACCEPTED

Mic Low Z 2V peak to peak
Mic Hi Z 12V peak to peak
Instrument 12V peak to peak

GAIN Mic 57dB High Z, 72dB Low Z
Instrument 44dB w/Gain switch out, Ch2
85dB w/Gain switch in, Ch1

SENSITIVITY Mic 3.5mV RMS High Z, 20mV RMS Low Z
Instrument 80mV RMS w/Gain switch out, Ch2
.8mV RMS w/Gain switch in, Ch1
Line In Insert 400mV RMS

EQS, MIC Low ± 15 dB @ 60Hz
Mid ± 15 dB @ 600Hz
High ± 15 dB @ 10kHz

EQS, INSTRUMENT Low 12.5dB range @ 80Hz
Mid 18dB range @ 800Hz
High 18dB range @ 10kHz
Shape Crate proprietary circuit

INSERT JACK Tip Line In
Ring Line Out
Sleeve Ground

SPEAKERS Woofer Crate Custom Design 10", 4 ohm, 100 watt
1.5" voice coil, 16 oz magnet
Tweeter 2" Piezo, 4 ohm, 150 watt network

POWER REQUIREMENTS Internal 12 volt DC power supply
DC adapter for use with 120VAC
Optional 12V vehicle lighter adapter

SIZE AND WEIGHT 15-1/2"W x 13"H x 12"D; 32 lbs.

The TX50D is covered with a durable Tolex® material. To keep the cabinet in top condition, wipe it clean with a damp, lint-free cloth to remove dirt and road film. Never spray cleaning agents directly onto the cabinet, and stay away from abrasive cleansers which could damage the finish.

Crate continually develops new products, as well as improves existing ones. For this reason, the specifications and information in this manual are subject to change without notice.



www.crateamps.com



©2001 SLM Electronics • A division of St. Louis Music
1400 Ferguson Avenue • St. Louis, MO 63133
P/N 47-099-03 • 061505