

CRATE

EL-10G ELECTRA SERIES GUITAR AMPLIFIER



OWNER'S MANUAL

Congratulations!

You are now the proud owner of the compact Crate EL-10G *Electra Series* Guitar Amplifier. The EL-10G features built-in overdrive circuitry, three bands of equalization, an insert jack and a jack for headphones.

In order to get the most out of your new amplifier, we strongly urge you to go over the information contained in this manual before you begin playing.

And ***thank you*** for choosing **CRATE**[®]

CRATE® EL-10G *Electra Series* Guitar Amplifier

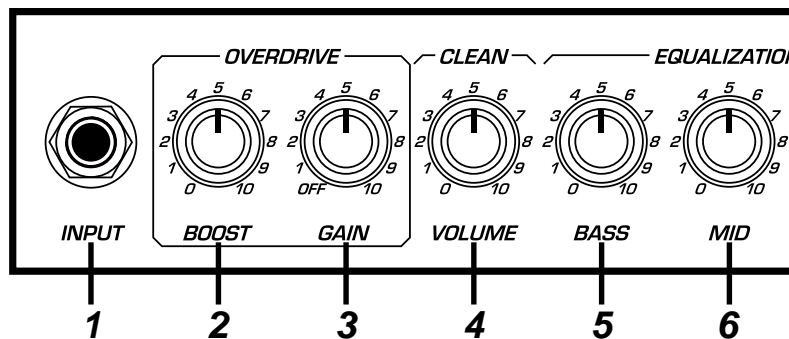

1: INPUT: Connect your guitar here using a shielded instrument cable.

2: OVERDRIVE BOOST: Increases the output volume and adds “crunch” to your sound. This control is only active when the Overdrive Gain control (#3) is turned on. For more information please see the “Getting Your Sound” section to the right.

3: OVERDRIVE GAIN: Controls the Overdrive Boost knob (#2) and adds distortion to your sound. This control is only active when turned on. For more information please see the “Getting Your Sound” section to the right.

4: CLEAN VOLUME: Controls the overall output level of the amp. For more information please see the “Getting Your Sound” section to the right.

5: BASS: Adjusts the low frequency output level: to the left reduces the low frequency output; to the right increases it.

6: MID: Adjusts the midrange frequency output level: to the left reduces the midrange frequency output, to the right increases it.

7: TREBLE: Adjusts the high frequency output level: to the left reduces the high frequency output; to the right increases it.

8: INSERT: Connect an external effects device via this jack. Use a stereo 1/4” male Y-cord: ring = send, tip = return, sleeve = ground. Send goes to the effect’s input; return comes from its output. (See the illustration on the panel to the right for more information.)

9: HEADPHONE: Plug a pair of stereo headphones here for private listening. When this jack is used the internal speakers and the external speaker jacks are disconnected.

10: POWER LED: This LED lights when the amplifier is powered up.

11: POWER SWITCH: Turns the amplifier on (in the UP position) and off (in the down position).

12: AC LINE IN: (Rear panel, not shown) This heavy-duty, grounded, three-wire power cord is to be plugged into ONLY a safely-wired, grounded 120 volt, 60 cycle AC power outlet. DO NOT attempt to defeat the ground connection of this cable! If your EL10G was purchased outside of the United States, see the unit’s rear panel for its power rating and follow the above guidelines.

CRATE[®] EL-10G Electra Series Guitar Amplifier

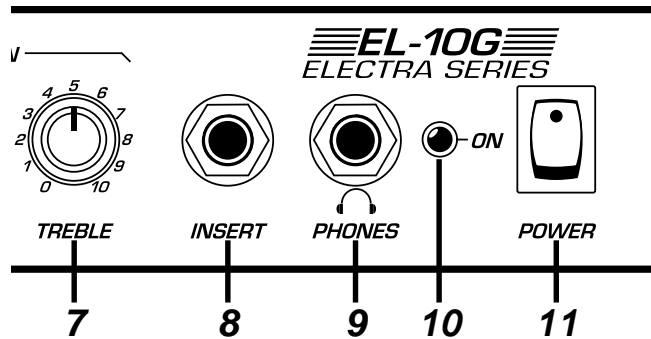

Getting Your Sound: The Boost, Gain and Volume controls (#2, 3 & 4) can be used together to obtain a wide variety of sounds. Experimenting with the following guidelines will help you get the sound you're looking for.

Clean Sounds: Keep the Gain control "off" (the Boost control will be inactive). Use the Volume control to set the output level.

"Crunch" Sounds: Set the Boost control around "4", turn the Gain on and set it to "2". Use the Volume control to set the output level. (A lower setting of the Volume control is needed as the Boost and Gain controls are increased.)

Rhythm Distortion: Set the Boost control around "4", Gain at or near "10". Use the Volume control to set the output level.

Lead Distortion: Set the Boost and Gain controls at or near "10". Use the Volume control to set the output level.

Connecting to the Insert jack: The Insert jack (#8) lets you patch external effects into the amplifier just prior to its power amp stage. Use Crate's STP201, STP202 or STP203 stereo-to-mono Y-cord or an adapter such as Crate's YPP117 and 2 1/4" mono signal cables to connect to the effect as shown:

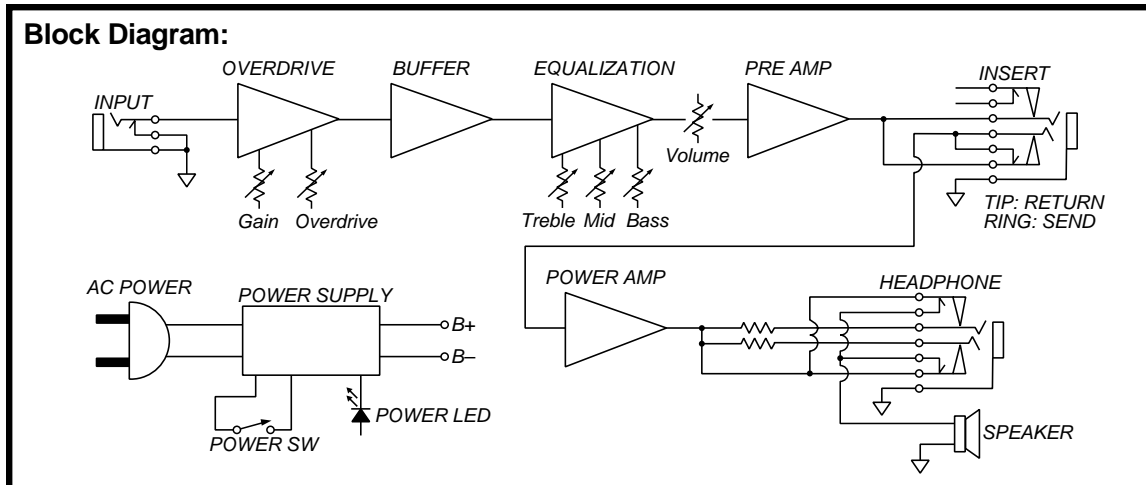
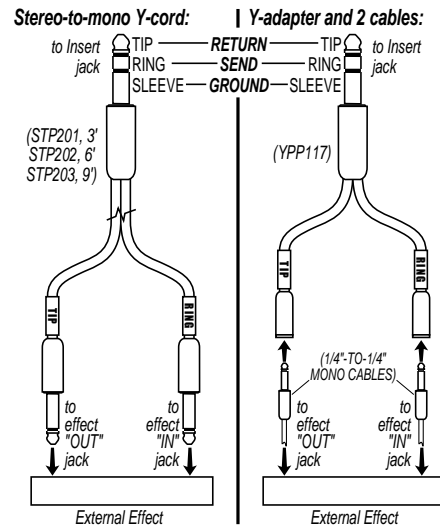





CRATE[®] EL-10G *Electra Series* Guitar Amplifier

EL10G TECHNICAL SPECIFICATIONS

Output Power Rating	10 watts @ 1% THD 14 watts @ 10% THD
Speaker Size	6"
Input Impedance	500k ohms
Minimum Noise	1mV
Maximum Noise	10mV
Distortion	0.9%
Input Power Requirements	120 VAC, 60Hz, 20VA 100/115VAC, 50/60Hz, 20VA 230VAC, 50/60Hz, 20VA
Cabinet Size and Weight	14" H x 12-1/2" W x 6" D, 12 lbs.

The EL-10G is covered with a black Tolex material: wipe it clean with a lint-free cloth. Never spray cleaning agents onto the cabinet. Avoid abrasive cleansers which could damage the finish.

 CAUTION RISK OF ELECTRIC SHOCK DO NOT OPEN	 ATTENTION RISQUE D'ELECTROCUTION NE PAS OUVRIR	 VORSICHT ELEKTRISCHE SCHLAGGEFAHR NICHT OFFENEN
CAUTION: TO REDUCE THE RISK OF ELECTRIC SHOCK, DO NOT REMOVE COVER. NO USER-SERVICEABLE PARTS INSIDE. REFER SERVICING TO QUALIFIED SERVICE PERSONNEL.	ATTENTION: POUR REDUIRE D'ELECTROCUTION NE PAS ENLEVER LE COUVERCLE. AUCUNE PIECE INTERNE N'EST REPARABLE PAR L'UTILISATEUR. POUR TOUTE REPARATION, S'ADRESSER A UN TECHNICIEN QUALIFIE.	VORSICHT: ZUR MINIMIERUNG ELEKTRISCHER SCHLAGGEFAHR NICHT DEN DECKEL ABENHMEN. INTERNE TEILE KONNEN NICHT VOM BENUTZER GEWARTET WERDEN. DIE WARTUNG IS QUALIFIZIERTEM WARTUNGSPERSONAL ZU UBERLASSEN.
<p>THIS EQUIPMENT HAS BEEN DESIGNED AND ENGINEERED TO PROVIDE SAFE AND RELIABLE OPERATION. IN ORDER TO PROLONG THE LIFE OF THE UNIT AND PREVENT ACCIDENTAL DAMAGES OR INJURY, PLEASE FOLLOW THESE PRECAUTIONARY GUIDELINES:</p> <p>CAUTION: TO REDUCE THE RISK OF ELECTRIC SHOCK, DO NOT OPEN CHASSIS; DO NOT DEFEAT OR REMOVE THE GROUND PIN OF THE POWER CORD; CONNECT ONLY TO A PROPERLY GROUNDED AC POWER OUTLET.</p> <p>WARNING: TO REDUCE THE RISK OF FIRE OR ELECTRIC SHOCK, DO NOT EXPOSE THIS EQUIPMENT TO RAIN OR MOISTURE.</p> <p>CAUTION: NO USER-SERVICEABLE PARTS INSIDE. REFER SERVICING TO QUALIFIED SERVICE PERSONNEL.</p> <p>CAUTION: OUR AMPLIFIERS ARE CAPABLE OF PRODUCING HIGH SOUND PRESSURE LEVELS. CONTINUED EXPOSURE TO HIGH SOUND PRESSURE LEVELS CAN CAUSE PERMANENT HEARING IMPAIRMENT OR LOSS. USER CAUTION IS ADVISED AND EAR PROTECTION IS RECOMMENDED IF UNIT IS OPERATED AT HIGH VOLUME.</p>		
EXPLANATION OF GRAPHICAL SYMBOLS: EXPLICACION DE SIMBOLOS GRAFICOS: EXPLICATION DES SYMBOLES GRAPHIQUES:	 = "DANGEROUS VOLTAGE" "VOLTAJE PELIGROSO" "DANGER HAUTE TENSION" "GEFAHLICHE SPANNUNG"	 = "IT IS NECESSARY FOR THE USER TO REFER TO THE INSTRUCTION MANUAL" "ES NECESARIO QUE EL USUARIO SE REFIERA AL MANUAL DE INSTRUCCIONES." "REFERREZ-VOUS AU MANUAL D'UTILISATION" "UNBEDINGT IN DER BEDIENUNGSANLEITUNG NACHSCHLAGEN"

Crate continually develops new products, as well as improves existing ones. For this reason, the specifications and information in this Crate manual are subject to change without notice.

CRATE[®]
www.crateamps.com

