

CRATE

BV300H

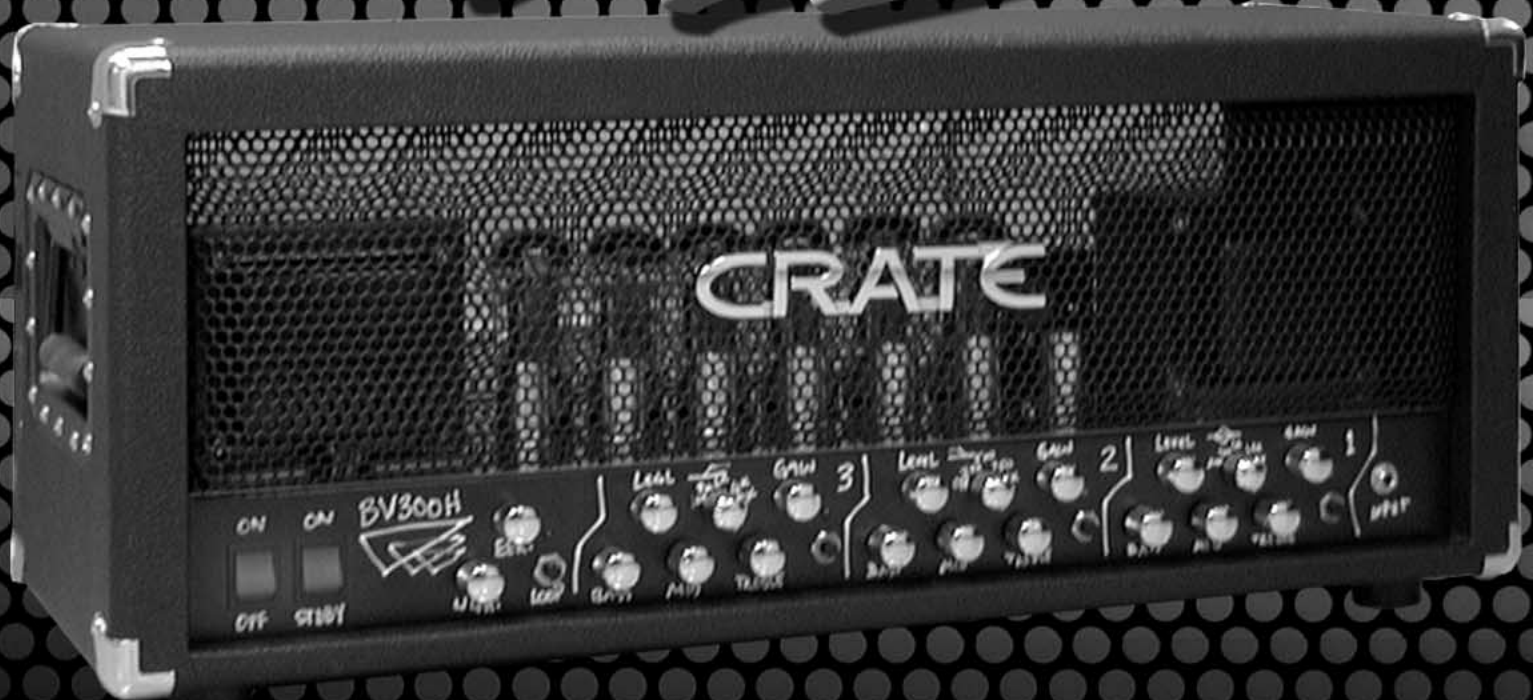
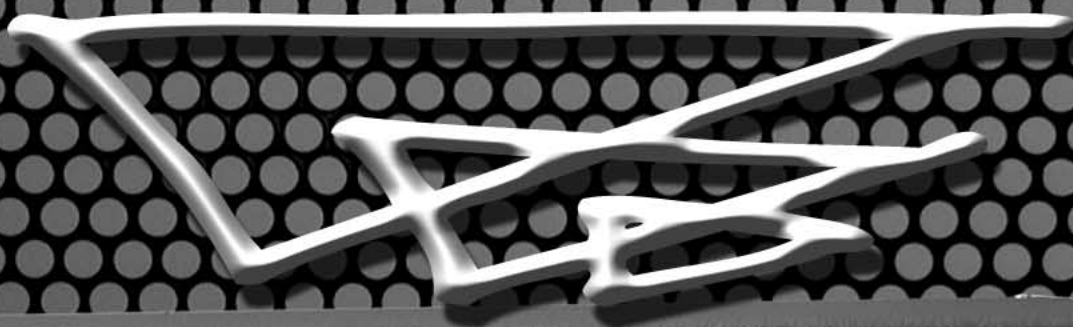

This is the operation guide for the Crate BV300H.

READ IT.

Then get ready for the Ride of your Life!



Contents:

A Message from the People Behind the BV300H 3

The Front Panel - Input & Channel 1 4

The Front Panel - Channel 2 5

The Front Panel - Channel 3 6

The Front Panel - Effects Loop, Eek & Ugh 7

The Rear Panel - Footswitch, Speaker Outputs, Slave Out 8

The Rear Panel - Effects Loop, Bias, AC Power 9

Important Information About Tubes and Tube Products

 A Brief History Of The Tube 10

 Tube Types And Usage 10

 The Nature Of Tubes: Why (And When) To Replace Them 11



 The Importance Of Proper Biasing 11

 Survival Tips For Tube Amplifiers 12

Some Suggested Settings 13

The Block Diagram 14

Technical Specifications 15

 CAUTION RISK OF ELECTRIC SHOCK DO NOT OPEN	 PRECAUCION RIESGO DE CORRIENTAZO NO ABRA	 ATTENTION RISQUE D'ELECTROCUTION NE PAS OUVRI
<small>WARNING: TO REDUCE THE RISK OF FIRE OR ELECTRIC SHOCK, DO NOT EXPOSE THIS APPARATUS TO RAIN OR MOISTURE. TO REDUCE THE RISK OF ELECTRIC SHOCK, DO NOT REMOVE COVER. NO USER-SERVICEABLE PARTS INSIDE. REFER SERVICING TO QUALIFIED SERVICE PERSONNEL.</small>	<small>PRECAUCION: PARA REDUCIR EL RIESGO DE INCENDIOS O DESCARGAS ELECTRICAS, NO PERMITA QUE ESTE APARATO QUEDE EXPUESTO A LA LLUVIA O LA HUMEDAD. PARA DISMINUIR EL RIESGO DE CORRIENTAZO, NO ABRA LA CUBIERTA. NO HAY PIEZAS ADENTRO QUE EL USUARIO PUEDO REPARAR DEJE TODO MANTENIMIENTO A LOS TECNICOS CALIFICADOS.</small>	<small>ATTENTION: PROTEGEZ CET APPAREIL DE LA PLUIE ET DE L'HUMIDITE AFIN D'EVITER TOUT RISQUE D'INCENDIE OU D'ELECTROCUTION. POUR REDUIRE D'ELECTROCUTION NE PAS OUVRIER LE COUVERCLE. AUCUNE PIECE INTERNE N'EST REPARABLE PAR L'UTILISATEUR. POUR TOUTE REPARATION, S'ADRESSER A UN TECHNICIEN QUALIFIE.</small>

IMPORTANT SAFETY INSTRUCTIONS

- READ, FOLLOW, HEED, AND KEEP ALL INSTRUCTIONS AND WARNINGS.
- DO NOT OPERATE NEAR ANY HEAT SOURCE AND DO NOT BLOCK ANY VENTILATION OPENINGS ON THIS APPARATUS. FOR PROPER OPERATION, THIS UNIT REQUIRES 3" (75CM) OF WELL VENTILATED SPACE AROUND HEATSINKS AND OTHER AIR FLOW PROVISIONS IN THE CABINET.
- DO NOT USE THIS APPARATUS NEAR SPLASHING, FALLING, SPRAYING, OR STANDING LIQUIDS.
- CLEAN ONLY WITH LINT-FREE DAMP CLOTH AND DO NOT USE CLEANING AGENTS.
- ONLY CONNECT POWER CORD TO A POLARIZED, SAFETY GROUNDED OUTLET WIRED TO CURRENT ELECTRICAL CODES AND COMPATIBLE WITH VOLTAGE, POWER, AND FREQUENCY REQUIREMENTS STATED ON THE REAR PANEL OF THE APPARATUS.
- PROTECT THE POWER CORD FROM DAMAGE DUE TO BEING WALKED ON, PINCHED, OR STRAINED.
- UNPLUG THE APPARATUS DURING LIGHTNING STORMS OR WHEN UNUSED FOR LONG PERIODS OF TIME.
- ONLY USE ATTACHMENTS, ACCESSORIES, STANDS, OR BRACKETS SPECIFIED BY THE MANUFACTURER FOR SAFE OPERATION AND TO AVOID INJURY.
- WARNING: TO REDUCE THE RISK OF ELECTRIC SHOCK OR FIRE, DO NOT EXPOSE THIS UNIT TO RAIN OR MOISTURE.
- SERVICE MUST BE PERFORMED BY QUALIFIED PERSONNEL.
- OUR AMPLIFIERS ARE CAPABLE OF PRODUCING HIGH SOUND PRESSURE LEVELS. CONTINUED EXPOSURE TO HIGH SOUND PRESSURE LEVELS CAN CAUSE PERMANENT HEARING IMPAIRMENT OR LOSS. USER CAUTION IS ADVISED AND EAR PROTECTION IS RECOMMENDED IF UNIT IS OPERATED AT HIGH VOLUME.



EXPLANATION OF GRAPHICAL SYMBOLS:
 EXPLICACION DE SIMBOLOS GRAFICOS:
 EXPLICATION DES SYMBOLES GRAPHIQUES:

 = "DANGEROUS VOLTAGE"
 "VOLTAJE PELIGROSO"
 "DANGER HAUTE TENSION"

 = "IT IS NECESSARY FOR THE USER TO REFER TO THE INSTRUCTION MANUAL"
 "ES NECESARIO QUE EL USUARIO SE REFIERA AL MANUAL DE INSTRUCCIONES."
 "REFERREZ-VOUS AU MANUAL D'UTILISATION"





A Message from the People Behind the BV300H:

You now own the finest lead guitar amplifier in the world. The Crate BV300H was designed to fulfill the needs of the professional musician. It is equally at home in the studio, in the club, or on the big stage. This amplifier has been designed with key features to finely sculpt its sound into YOUR sound. The BV300H uses premium materials and workmanship and is made entirely in the U.S.A. It includes a full 5 year warranty on parts and labor and a 90 day warranty on tubes. Unlike some other amplifiers which only sound good when turned up, the BV300H delivers the same awesome tone at low volumes that it does at high stage levels. This is due to our unique power amplifier that produces the same sweet, warm juicy tone at ANY level. 3 watts or 300 watts, the tone is consistent, strong and powerful.

Don't let the 300W rating scare you. All amplifiers can benefit from added headroom. 300 watts allows the player to hear the detail and dynamics of the sound much better. The sound is like nothing you have ever heard before. Imagine palm muting the low strings and actually hearing the full dynamic. Many players don't even know what this sounds like because their amplifiers are underpowered. Have you ever started to turn your amplifier up louder only to have the tone change, get flubby, fart out... Lack of headroom. The only way to describe it is to experience it.

Coupled with its massive power amplifier is a state of the art 3 channel preamp. Switching is accomplished via momentary switches that provide instant access to each of the 3 channels.

A classic design originally used for bass or guitar, Channel 1 is full of dynamic headroom and tonal versatility. It utilizes a clean, punchy preamplifier section with classic high and low tone EQs and a 5-position midrange selector to further dial in your tone.

Channel 2 has a classic british tonality that will be familiar to most players. The warmth and crunch of a naturally overdriven power amp is captured powerfully by this channel. Touch sensitivity and dynamics are emphasized in this traditionally voiced preamp. This channel provides creamy-smooth overdrive, with a slight compression effect.

Channel 3 is the power driver. It delivers the goods in a forceful, aggressive manner with the slightest amount of tube compression. Voiced quite a bit harder than Channel 2, Channel 3 is like a sledgehammer pounding away.

Rounding out the front panel controls are a pair of power amp feedback controls, Eek and Ugh. Use them for tuning the amplifier to different cabinets or rooms.

The rear panel consists of an array of speaker outputs, 1/4" and Neutrik Speakon®, slave output with level control, bias controls and test points, and the effects loop with level controls - switchable for series or parallel operation. The loop can be engaged from the front panel switch or the supplied BVFS4 footswitch.

THE FRONT PANEL - Input, Channel 1:

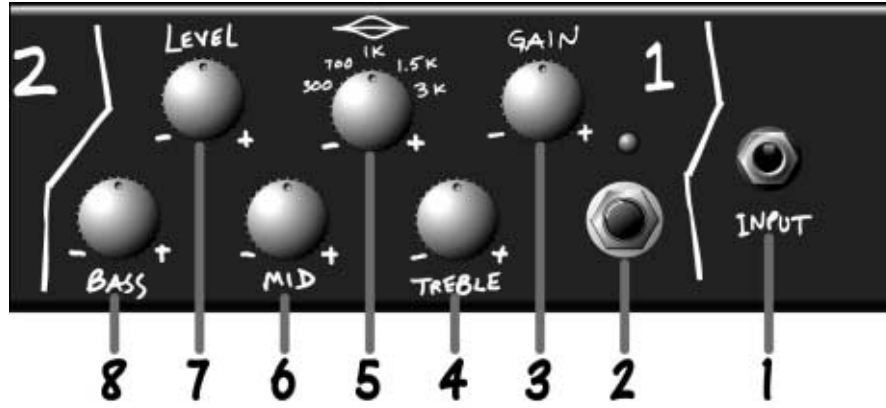

1. Input Jack: 1 Meg Ohm input impedance 1/4" input jack - plug your guitar in here.

2. Channel 1 Select Switch: When you want to use Channel 1, press this switch. The green LED above this switch lights up when Channel 1 is selected. The BV300H uses instant access switching - when the footswitch (#28, rear panel) is connected, either the front panel channel select switches or the footswitch will select the desired channel.

3. Gain: Use this control to adjust the input gain for Channel 1. Towards the "-" side gives you tight, dynamic clean tones. Towards the "+" side you'll get more crunch. Using a circuit that was originally used for the bass or guitar, the gain is mild, yet thick & punchy. (A humbucker will push the preamp intensely into compression.)

4. Treble: Use this control to adjust the top end level for Channel 1. The Treble control

provides a range of 38dB at 5kHz.

5. Mid Freq Select: Use this control to select the frequency where the Mid control takes effect - 300Hz, 700Hz, 1kHz, 1.5kHz, or 3kHz.

6. Mid: Use this control to adjust the midrange level for Channel 1. The Mid control gives you 10dB of boost or 22dB of cut at whatever frequency the Mid Freq control (#6) is set to. The Mid control is a peak/dip style filter.

7. Level: Use this control to adjust the output level of Channel 1. Along with the Gain control (#3), you can get the right blend of dynamics for your playing style.

8. Bass: Use this control to adjust the low end level for Channel 1. The Bass control provides 24dB of boost or cut at 50Hz.

THE FRONT PANEL - Channel 2:

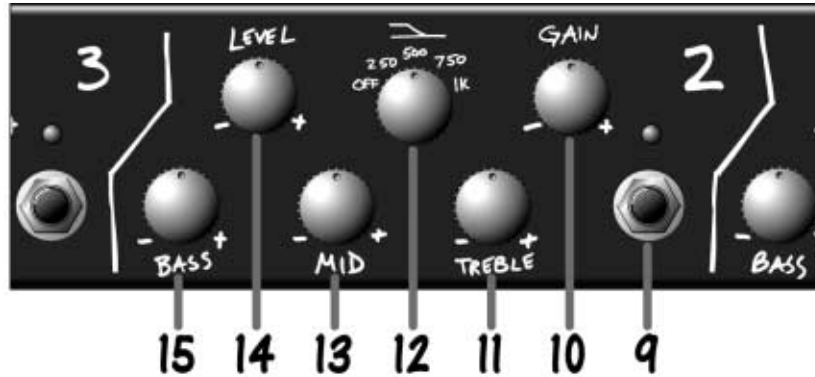

9.Channel 2 Select Switch: When you want to use Channel 2, press this switch. The amber LED above this switch lights up when Channel 2 is selected. The BV300H uses instant access switching - when the footswitch (#28, rear panel) is connected, either the front panel channel select switches or the footswitch will select the desired channel.

10.Gain: Use this control to adjust the input gain for Channel 2. Towards the "-" side gives you the classically British warm crunch. Towards the "+" side gives you creamy smooth overdrive with a touch of compression.

11.Treble: Use this control to adjust the top end level for Channel 2. The Treble control provides 12dB of boost or cut at 2kHz.

12.Mid Boost Select: Use this control to add a 4~5dB boost from the low end up to the midrange frequency selected: 250Hz, 500Hz, 750Hz, or 1kHz. There is, of course, no boost when this control is at the "off" position.

13.Mid: Use this control to adjust the midrange output level for Channel 2. The Mid control gives you 10dB of boost or cut at 750Hz.

NOTE: The Mid Boost Select (#12) uses a different circuit than the Mid control (#13).

14.Level: Use this control to adjust the output level of Channel 2. Use this control along with the Gain control (#10) to get the sound you're looking for on Channel 2.

15.Bass: Use this control to adjust the low end level for Channel 2. The Bass control provides 20dB of boost or cut at 50Hz.

THE FRONT PANEL - Channel 3:

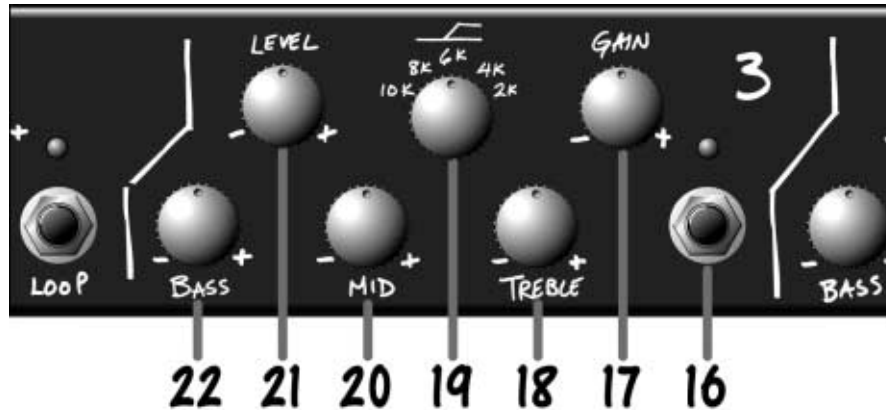

16.Channel 3 Select Switch: When you want to use Channel 3, press this switch. The red LED above this switch lights up when Channel 3 is selected. The BV300H uses instant access switching - when the footswitch (#28, rear panel) is connected, either the front panel channel select switches or the footswitch will select the desired channel.

17.Gain: Use this control to adjust the input gain for Channel 3. Towards the "-" side gives you a punchy tube sound perfect for aggressive rhythm playing. Towards the "+" side and you're asking for some seriously aggressive tones!

18.Treble: Use this control to adjust the top end level for Channel 2. The Treble control provides 25dB of boost or cut at whatever frequency the High Freq control (#19) is set to.

19.High Freq Select: Use this control to choose the frequency where the High control takes effect - 10kHz, 8kHz, 6kHz, 4kHz or 2kHz.

20.Mid: Use this control to adjust the midrange level for Channel 3. The Mid control provides 20dB of boost or cut at 1.2kHz.

21.Level: Use this control to adjust the output level of Channel 3. Use this control along the Gain control (#17) to get the sound you're looking for on Channel 3.

22.Bass: Use this control to adjust the low end level for Channel 3. The Bass control provides 18dB of boost or cut at 100Hz.



THE FRONT PANEL - Effects Loop, Eek & Ugh:

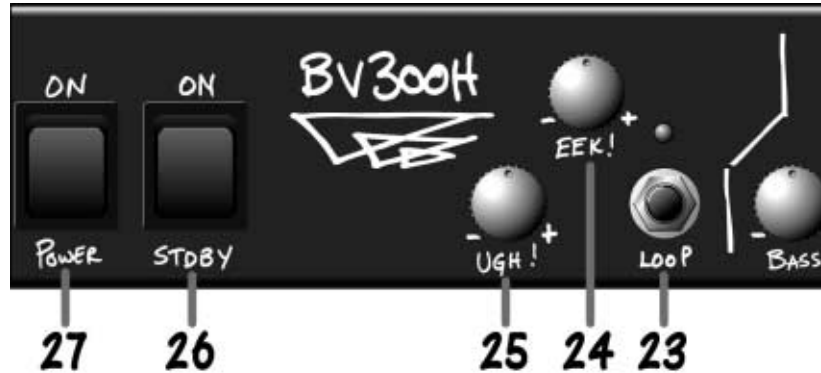

23. Loop Switch: When you want to engage the rear panel effects loop, press this switch. The blue LED above this switch lights up when the effects loop is active. This can be used as a "boost" feature - see the "Hot Tip" on page 9. The BV300H uses instant access switching - when the footswitch (#28, rear panel) is connected, either the front panel loop switch or the footswitch will activate the effects loop.

24. Eek!: This is your high frequency power amp damping control. This is used to add definition and edge to your sound. The Eek! control helps to compensate for dark rooms and/or speaker cabinets.

25. Ugh!: This is your low frequency power amp damping control. This is used to control and shape the low end. Towards the "-" side tightens up the bass and controls the speaker cones better. Towards the "+" side makes it more "thumpy" and allows the speaker cones to move easier.

26. Standby Switch: Use this switch to put the amplifier into "Stand By" mode - the tube filaments are still turned on, but the high voltage is deactivated.

NOTE: The Power switch must be turned on for at least ONE MINUTE before you turn on the Standby switch (#26).

27. Power Switch: Use this switch to turn the amplifier on and off.

THE REAR PANEL - Footswitch, Speakers, Slave Out:

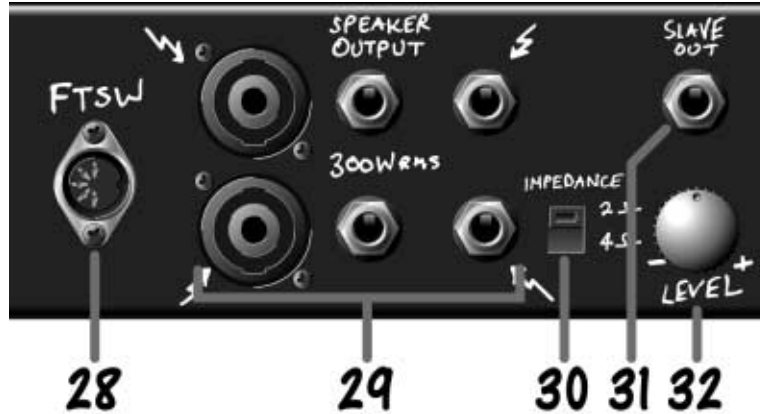

28. Footswitch Jack: Use this jack to connect the BVFS4 four-button footswitch to the amplifier. This allows you to switch channels and turn the effects loop on and off - by remote foot control. Connect one end of the supplied footswitch cable* to this jack, the other end to the footswitch.

29. Speaker Output Jacks: Use these jacks to connect your speaker cabinet(s) to the amplifier. The wiring for the Speakon® jacks is Pin 1+ = hot, Pin 1- = ground.

All six Speaker Output jacks are wired in parallel, which lets you connect the amp to a bunch of cabinets.

The minimum gauge of the wiring used for these connecting cables should be 16GA!

30. Impedance Switch: Use this switch to match the amplifier to the total impedance of your speaker cabinets. Use the following chart and make sure that this switch is at the proper setting before playing!

IMPEDANCE OF CABINETS	NUMBER OF CABINETS	TOTAL IMPEDANCE
16 ohms	8	2 ohms
16 ohms	4	4 ohms
8 ohms	4	2 ohms
8 ohms	2	4 ohms
4 ohms	2	2 ohms

31. Slave Out Jack: Use this jack to connect the amp to a slave amplifier, PA amp, or recording console. The signal at the Slave Out jack is an attenuated version of the signal at the Speaker Output jacks.

NOTE: The signal at the Slave Out jack is capable of potentially damaging certain equipment. Make sure the Slave Out Level control is all the way down before connecting anything to the Slave Out jack. Then **slowly** increase the Level control!

Never use the Slave Out if the amplifier is not connected to a speaker cabinet!

32. Slave Out Level: Use this knob to adjust the output level of the Slave Out signal (#31).

***NOTE:** You **MUST** use a 5-wire MIDI cable when connecting the BVFS4 to the amplifier for proper operation of the footswitch.



The BVFS4 footswitch - select channels & turn the effects loop on and off with just a tap of your foot!

THE REAR PANEL - Effects Loop, Bias, AC Power:

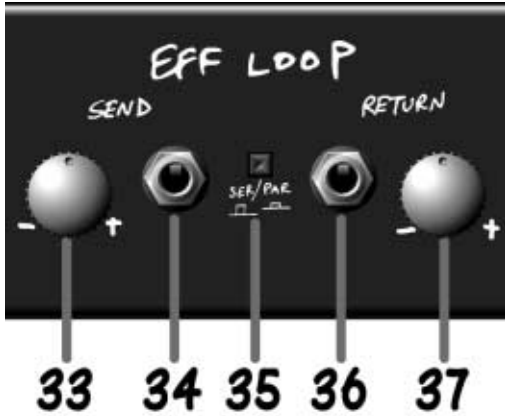

33. Effects Loop Send Level: Use this knob to adjust the level of the Effects Loop Send signal (#34). Some effects are picky as to what they like for an input level, so use this knob to get them to smile.

34. Effects Loop Send Jack*: When connecting the amp to an external effects device, use this jack to send the signal to the Input jack of the effect.

35. Series/Parallel Switch: Use this switch to configure the effects loop in series or in parallel with the signal path. Certain effects sound better one way than the other.

36. Effects Loop Return Jack*: When connecting the amp to an external effects device, use this jack to return the signal from the output of the effects device back into the amplifier.

37. Effects Loop Return Level: Use this knob to adjust the level of the Effects Loop Return signal (#36). Some effects have hotter outputs than others, so use this knob to adjust the return signal level for the best level of effect.

38. Bias Controls: Authorized Service personnel use this section to work their magic on the amplifier. Like it says on the amp: **Don't mess with the Bias!** Your Authorized Crate Service Center will have all the information needed to re-bias your amplifier if and when it becomes necessary.

39. Fuse: The fuse helps protect the amplifier against damage from faulty AC line voltages and other possible problems. If the amp stops working, check the fuse. If the fuse is blown, replace it **ONLY** with the exact same size and type as indicated! If the problem persists, contact your Authorized Crate Service Center.

40. AC Inlet Jack: Insert the female end of the power cord firmly into this jack. The grounded power cord should only be plugged into a grounded power outlet that meets all applicable electrical codes and is compatible with the voltage, power, and frequency requirements stated on the rear panel. **Do not attempt to defeat the safety ground connection!**

***HOT TIP!** If you connect a signal cable from the Effects Loop Send jack (#34) to the Effects Loop Return jack (#36), the loop level control adjust the amount of boost engaged - up to 6dB in the series mode, up to 9dB in the parallel mode!



Important Information About Tubes And Tube Products:

A Brief History Of The Tube:

In 1883, Edison discovered that electrons would flow from a suspended filament when enclosed in an evacuated lamp. Years later, in 1905, Fleming expanded on Edison's discovery and created the "Fleming Valve". Then, in 1907, Dr. Lee de Forest added a third component - the grid - to the "Fleming's Valve" and the vacuum tube was a fact of life. The door to electronic amplification was now open.

During World War II, data gleaned from their intensive research on the detectors used in radar systems led Bell Telephone Laboratories to the invention of the transistor. This reliable little device gained quick support as the new component for amplification. The death of the vacuum tube seemed imminent as designers, scientists, and engineers reveled in the idea of replacing large, fragile glass tubes with these small, solid-state devices.

However, there were (and still are) many serious listeners who realized that the sound produced by a "transistor" amplifier is significantly different from that produced by a tube amplifier with identical design specifications. They considered the sound produced by these new solid-state devices to be hard, brittle, and lifeless. It was determined that solid-state devices produced a less musical set of harmonics than tubes. When pushed past their limits, they tend to mute the tone and emphasize the distortion.

Tubes, on the other hand, produce a more musical set of harmonics, the intensity of which can be controlled by the player. This characteristic adds warmth and definition to the sound which has become the hallmark of tube amplifiers. When tubes are driven into clipping, the harmonic overtones can be both sweet and pleasing or intense and penetrating, depending on the musician's musical taste and playing technique.

Over the years, application engineers have designed a number of outstanding solid-state amplifiers that sound very, very good. Some use special circuitry which enables them to simulate the distortion characteristics of a tube amplifier. However, the tube amplifier, still held in the highest esteem by many musicians, offers a classic "vintage" sound in a contemporary market.

Tube Types And Usage:

Tube amplifiers are based primarily on two types of tubes - preamplifier tubes and power tubes. The tubes used in preamplifiers (12AX7, 12AU7, 12AT7, etc.) are smaller than the power tubes. These tubes amplify the signal from your instrument and shape the sound. They are inherently microphonic (mechanically pick up and transmit external noises). Since these tubes are used in the critical first stages of a tube amplifier's circuitry, it is very important to use high-quality, low noise/low microphonic tubes for this application. Although tubes of this quality may be difficult to find and typically cost more than "off-the-shelf" tubes, the improvement in performance is worth the investment.

Preamplifier tubes are also used to drive the power tubes. When used in this application, a 12AX7 will produce a more distorted tone than a 12AT7, which produces a clearer, sweeter sound. A 12AU7 is even cleaner and brighter than a 12AT7, giving more definition to the sound. (In some cases it is possible to change the sound by changing the type of preamp and/or driver tubes. When making any modification to your equipment, it is highly recommended that you consult with a qualified service center.)

The power tubes are the largest tubes used in an amplifier. These tubes convert the low-level, conditioned signal from the preamplifier into a level that is sufficient to drive the speakers. There are several types of power tubes available, each of which offers a different performance/sound characteristic. For example, the EL34 power tube produces a great Classic rock sound. When an EL34 is driven into distortion it produces a unique sound ("crunch"). When compared to the 6L6, the EL34 distorts more quickly, exhibits a "looser" low-end response and produces more harmonics at mid and high frequencies ("creamier" sound). These differences become more noticeable at higher volumes.

The 6L6 tubes produce a big low-end thump and have a very good dynamic range. They offer a more traditional "American Rock" sound. The 6V6 tubes produce a creamy sound with nice distortion. On the other hand, the KT88 produces a big low-end but sounds more like an EL34 in the mid and high frequencies.

The 6550 power tubes are more rugged and stay cleaner sounding even at full power. When they do distort, the sound produced is more solid and has a tighter low end; more of a "heavy metal" type distortion with lots of power.

Some tubes are available in matched sets. These tubes have been extensively tested for optimum performance and longevity.



The Nature Of Tubes: Why (And When) To Replace Them:

Tubes are made up of a number of fragile mechanical components that are vacuum-sealed in a glass envelope or bubble. The tube's longevity is based on a number of factors which include how hard and often the amplifier is played, vibration from the speakers, road travel, repeated set up and tear down, etc.

Any time you notice a change in your amplifier's performance, check the tubes first.

If it's been a while since the tubes were replaced and the sound from your amplifier lacks punch, fades in and out, loses highs or lows or produces unusual sounds, the power tubes probably need to be replaced. If your amplifier squeals, makes noise, loses gain, starts to hum, lacks "sensitivity", or feels as if it is working against you, the preamplifier tubes may need to be replaced.

The power tubes are subjected to considerably more stress than the preamplifier tubes. Consequently, they almost always fail/degrade first. If deteriorating power tubes aren't replaced they will ultimately fail. Depending on the failure mode, they may even cause severe damage to the audio output transformer and/or other components in the amplifier. Replacing the tubes before they fail completely has the potential to save you time, money and unwanted trouble. Since power tubes work together in an amplifier, it is crucial that they (if there is more than one) be replaced by a matched set. If you're on the road a lot, we recommend that you carry a spare matched set of replacement power tubes and their associated driver tubes.

After turning off the power and disconnecting the amplifier from the power source, carefully check the tubes (in bright light) for cracks or white spots inside the glass or any other apparent damage. Then, with the power on, view the tubes in a dark room. Look for preamplifier tubes that do not glow at all or power tubes that glow excessively red.

Whenever you replace the power tube(s):

- Always have the amplifier's bias voltage checked by a qualified service center. Improper bias voltage will cause degradation in performance and possibly damage the tubes and/or the amplifier. (See the section below entitled, "The Importance of Proper Biasing", for more information on this subject).
- We highly recommend that you replace the driver tube(s) as well. The driver tube determines the shape and amplitude of the signal applied to the power tube(s) and has to work almost as hard as the power tube(s).

You can check your preamplifier tubes for microphonics by turning the amplifier on, turning up the gain and tapping lightly on each tube with the end of a pencil or a chop stick (my favorite). You will be able to hear the tapping through your speakers, which is normal. It is not normal for a tube to ring like a bell after it's tapped. If it does ring then it's microphonic and should be replaced. Remember to use only high quality, low microphonic tubes in the preamplifier section.

Even though power tubes are rarely microphonic, you should check them anyway. The power tubes can be checked for microphonics just like pre-amp tubes.

In the case of very high gain amps, you may be able to reduce the amount of noise generated by simply swapping the preamp tubes around.

The Importance Of Proper Biasing:

For the best performance and longest tube life, proper biasing is imperative. Bias is the negative voltage which is applied to the power tube's control grid to set the level of idle current. We cannot overemphasize the difference in warmth of tone and dynamic response that come with proper biasing. If the bias is set too high (overbiased), the sound from the amp will be distorted at all levels. If the bias is set too low, (under biased) the power tubes will run hot (the plates inside the tubes may glow red due to excessive heat) and the sound from the amplifier will lack power and punch. The excessive heat greatly reduces tube life - from a few days to as little as a few hours in extreme cases. Setting the bias on your amp is like setting the idle on your car. If it's too high or hot it's running away with you and if it's too low or cold it will choke when you step on it.

The bias is adjusted at the factory in accordance with the type of power tube(s) installed in your amplifier. It is important to point out that tubes of the same type and specification typically exhibit different performance characteristics. Consequently, whenever power tubes are replaced, the bias voltage must be checked (unless the amplifier is equipped with "self-biasing circuitry) and readjusted to accommodate the operating parameters of the replacement tubes.

Depending on the model and amplifier type, there may be hum balance controls, trim pots, or bias adjustment controls on its rear panel. However, the bias adjustment should be performed only by qualified service personnel with the proper, calibrated test equipment.



Survival Tips For Tube Amplifiers:

To prolong tube life, observe these tips and recommendations:

- Match the impedance of your speaker cabinet(s) to your amplifier. Improper impedance matching will contribute to early tube degradation and may cause premature tube failure.
- Make sure the speaker(s) are properly connected prior to turning on the amplifier.
- After playing the amplifier, allow sufficient time for it to properly cool down prior to moving it. A properly cooled amplifier prolongs tube life due to the internal components being less susceptible to the damage caused by vibration.
- Allow the amplifier to warm up to room temperature before turning it on. The heat generated by the tube elements can crack a cold glass housing.
- Replace the output tube(s) before the performance degrades or the tubes fail completely. Replace the tube(s) on a regular basis (at least once per year or as often as every 4 to 6 months if you play long and hard every day).
- Always have the bias checked after replacing the output tubes (unless the amplifier is equipped with "self-biasing circuitry"). This should be done ONLY at a qualified service center. Improper biasing could result in the tubes running too hot, which greatly reduces the life of the tubes - or too cold, which results in distorted sound regardless of level settings. Do not play the amplifier if it exhibits these symptoms - get the bias checked/adjusted immediately to prevent tube failure and/or other damage.
- If the locating notch on the base of a power tube breaks off, replace the tube. This significantly reduces the risk of damaging your amplifier by incorrectly inserting the tube.
- Protect the amplifier from dust and moisture. If liquid gets into the amplifier proper, or if the amplifier is dropped or otherwise mechanically abused, have it checked out at an authorized service center before using it.
- Proper maintenance and cleaning in combination with routine checkups by your authorized service center will insure the best performance and longest life from your amplifier.

CAUTION: Tube replacement should be performed only by qualified service personnel who are familiar with the dangers of hazardous voltages that are typically present in tube circuitry.

Some Suggested Settings:

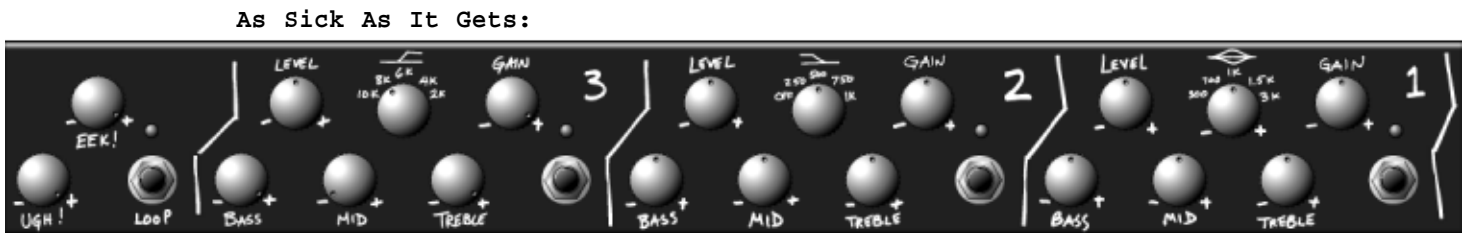
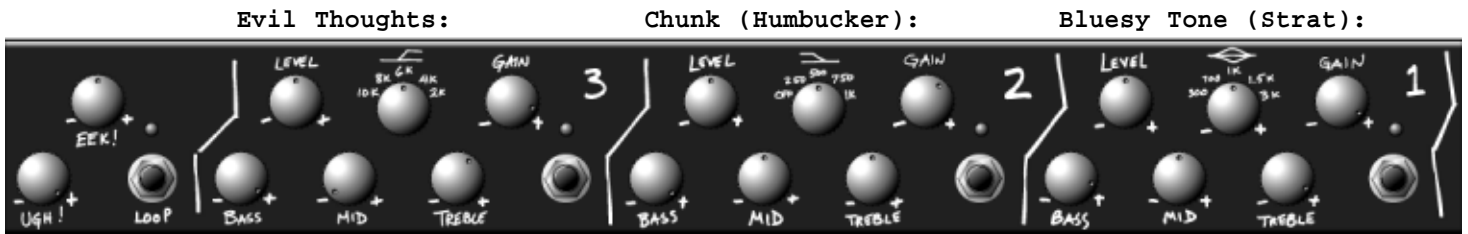

The Block Diagram:

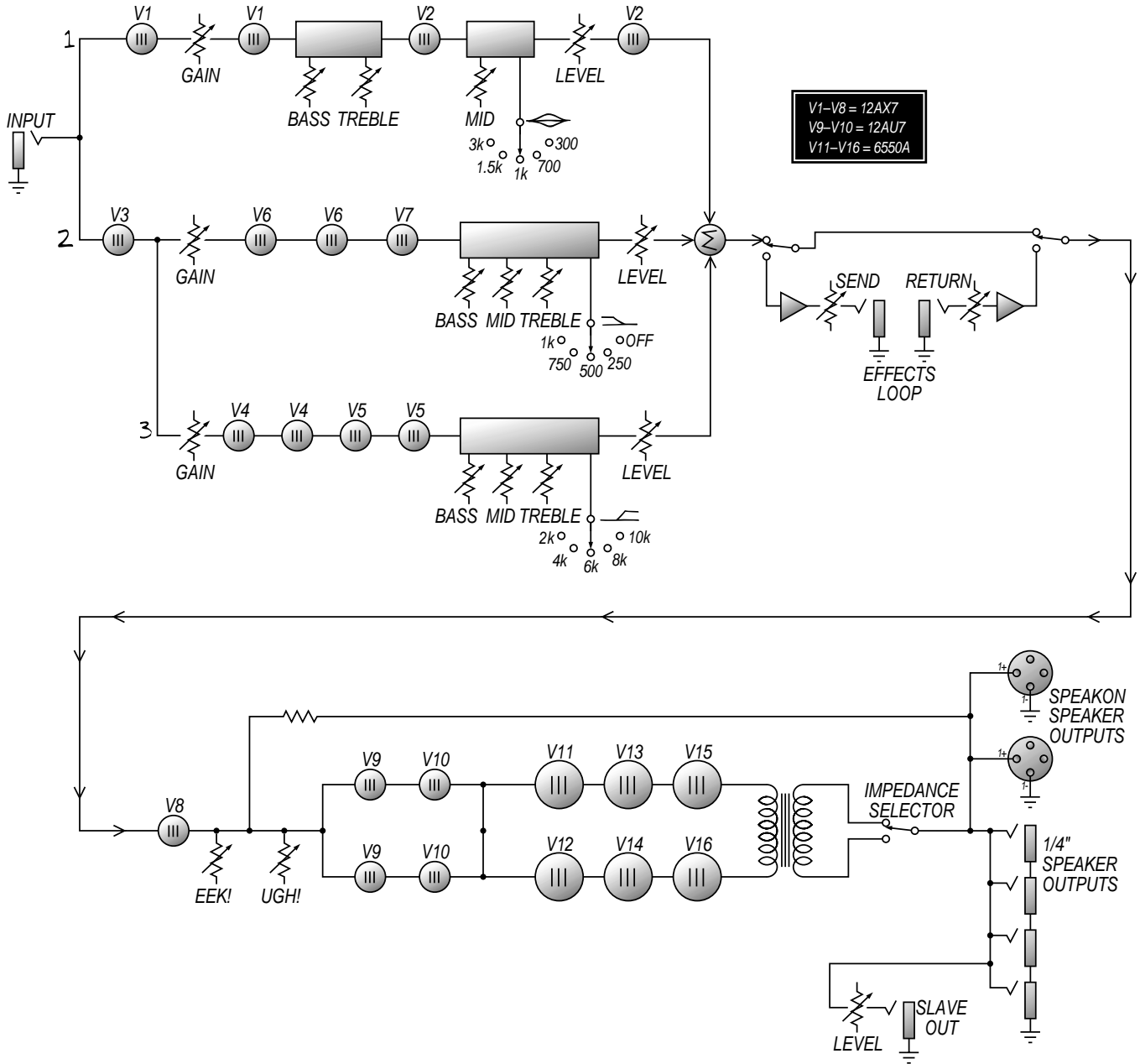



Technical Specifications:

OUTPUT POWER RATING	300 Watts RMS @ 5% THD, 4 ohm load, 120 VAC		
SIGNAL TO NOISE RATIO	75dB Typical		
GAIN	Channel 1	Channel 2	Channel 3
	80dB	105dB	105dB
EQs	Channel 1	Channel 2	Channel 3
LOW	24dB range @ 50Hz	20dB range @ 50Hz	18dB range @ 100Hz
MID	+10/-22dB @ EQ Switch	10dB range @ 750Hz	20dB range @ 1.2kHz
EQ SWITCH	300,700,1k,1.5k or 3kHz	+4-5dB @ 250,500,750 or 1kHz	2k, 4k, 6k, 8k or 10kHz
HIGH	38dB range @ 5kHz	12dB range @ 2kHz	25dB range @ EQ Switch
REJECTION	6dB @ 5kHz		
ATTEN	5dB below 250Hz		
PREAMP TUBES	(8) 12AX7A, (2) 12AU7		
POWER TUBES	(6) 6550A		
POWER REQUIREMENTS	120 VAC, 60 Hz, 600VA		
	100/115 VAC, 50/60 Hz, 600VA		
	230 VAC, 50/60 Hz, 600VA		
SIZE AND WEIGHT	30"W x 12-1/2" H x 11"D, 80 lbs.		

Specifications and information subject to change without notice.

The BV300H is covered with heavy duty Tolex® - wipe it clean from time to time with a soft damp cloth.

Declaration Of Conformity	
#35, Effective 01-01-2001	
Manufacturer's Name:	SLM Electronics
Production Facility:	1901 Congressional Drive, St. Louis, MO 63146, USA
Production Facility:	700 Hwy 202 W, Yellville, AR 72687, USA
Shipping Facility:	1400 Ferguson Ave., St. Louis, MO 63133, USA
Office Facility:	1400 Ferguson Ave., St. Louis, MO 63133, USA
Product Type:	Audio Amplifier
Complies with Standards:	
LVD:	92/31/EEC, 93/68/EEC, & 73/23/EWG
Safety:	EN60065
EMC:	EN55013, EN55020, EN55022, EN61000-3-2, & EN61000-3-3
Supplementary information provided by: SLM Electronics - R & D Engineering 1901 Congressional Drive, St Louis, MO 63146, USA Tel.: 314-569-0141, Fax: 314-569-0175	



www.crateamps.com

©2002 SLM Electronics • A division of St. Louis Music, Inc. • 1400 Ferguson Avenue • St. Louis, MO 63133

